

## Capacitive level sensor

for conductive and non-conductive liquids

### BODY

Brass.

### ELECTRODE

Copper – Zinc Alloy (Cu-Zn Alloy), with coating in PTFE.

### FEMALE CONNECTOR (DIN 43650 C)

Polyamide-based technopolymer (PA), black colour, with built-in cable gland and contact holder.  
IP65 protection class, according to EN 60529 (on page -).

### MALE CONNECTOR

Connector M12x1 - 4-pin with thread in polyamide-based (PA) technopolymer, black colour, matte finish.  
IP 67 protection class.

For a correct assembly see Warnings.

### STANDARD EXECUTIONS

- **HSC-W-A:** for conductive liquids, enabled NPN electrical output
- **HSC-W-D:** for conductive liquids, disabled NPN electrical output
- **HSC-O-A:** for non-conductive liquids, enabled NPN electrical output
- **HSC-O-D:** for non-conductive liquids, disabled NPN electrical output
- **KN:** suffix to be added for versions with M12x1 male connector.

### MAX. WORKING TEMPERATURE

-30 / +125°C.

### MAXIMUM WORKING PRESSURE

50 bar.

### FEATURES AND APPLICATIONS

Suitable for the detection of conductive liquids such as water and non-conductive liquids such as oil/diesel.

The sensor activation delay, equal to 4 seconds, represents the time elapsed between the detection of the level inside the tank and the sending of the signal to the PLC.

The differential required for the calibration of the output signal hysteresis is calculated starting from the point of intervention (I1) and represents the virtual point of intervention obtained by adding the value of the differential to the value I1.

The sensor can be mounted both vertically and horizontally.

### SPECIAL EXECUTIONS ON REQUEST

- AISI 316 stainless steel body.
- Probe length 90 mm.
- Option to have the activation delay preset between 1 and 10 sec.
- Option to have calibration differential preset between 0 and 5 mm.
- Male threads Cylindrical gas UNI 228/1 or Conical gas UNI 7/1.

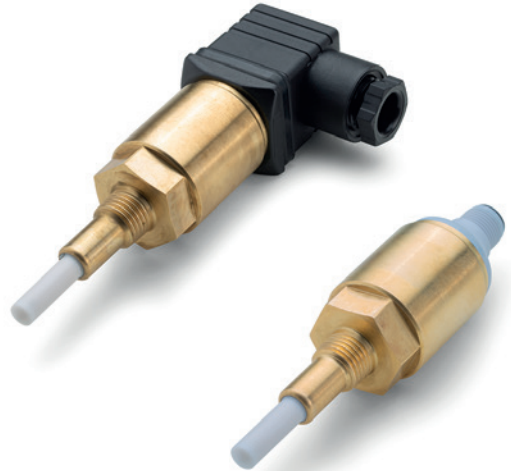

### CONNECTOR ASSEMBLY INSTRUCTIONS

1. Remove the connector from the sensor by unscrewing the set screw placed on the connector, take the contact holders out and loosen the cable gland.
2. Insert the cable into the connector (standard connector) and connect the wires to the clamps, as indicated in the wiring instructions.
3. Assemble by pressing the contact holder into the connector in the required position.
4. Screw the connector to the sensor and then tighten the cable gland.

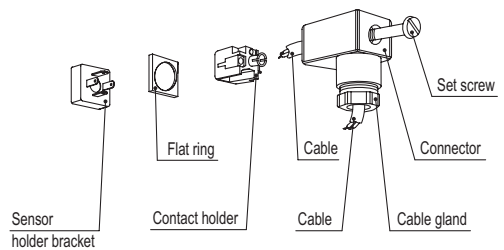

### HSC

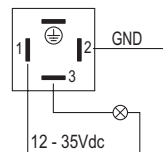

### HSC-KN

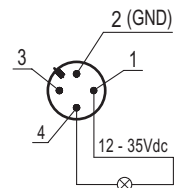

Electrical features	
Description	Features
Power supply	15 – 35 Vcc
Current drawn by the internal circuit	5 mA
Electrical output	Push - Pull
Max load	3W
Activation delay	4 sec
Differential	3 mm

**FUNCTIONING AND MAINTENANCE**

The level measurement is based on the variation of the electrical capacity inside the tank; the level probe and the metal wall create a sort of capacitor whose electrical capacity varies according to the quantity of liquid contained in the tank itself.

As the level inside the tank increases, the electrical capacity of the probe increases accordingly.

For example, an empty tank has a lower electrical capacity, while a full tank has a higher one.

The sensor can be mounted both vertically and horizontally (Fig.1). It is advisable to periodically check the condition of the electrode and its coating and, if necessary, proceed with cleaning using non-corrosive liquids.

**WARNINGS**

For both installation solutions, horizontal on the side of the tank or vertical, it is necessary to avoid installing the sensor on connecting tubes where vapours could condense or residues could remain which could affect the detection.

Fig.1

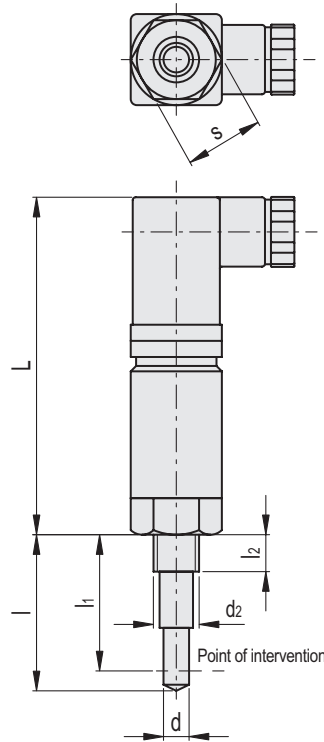
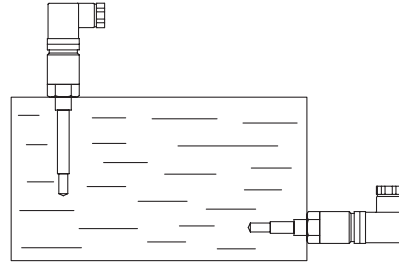

**HSC-W-A**

Code	Description	d2	d	L	l'	l1	l2	s	ΔΔ
111251	HSC-W-1/4NPT-50-A	1/4 NPT	6.5	77	50	40±2	10	24	140

**HSC-W-D**

Code	Description	d2	d	L	l'	l1	l2	s	ΔΔ
111252	HSC-W-1/4NPT-50-D	1/4 NPT	6.5	77	50	40±2	10	24	140

**HSC-O-A**

Code	Description	d2	d	L	l'	l1	l2	s	ΔΔ
111241	HSC-O-1/4NPT-50-A	1/4 NPT	6.5	77	50	40±2	10	24	140

**HSC-O-D**

Code	Description	d2	d	L	l'	l1	l2	s	ΔΔ
111242	HSC-O-1/4NPT-50-D	1/4 NPT	6.5	77	50	40±2	10	24	140

\* Probe length



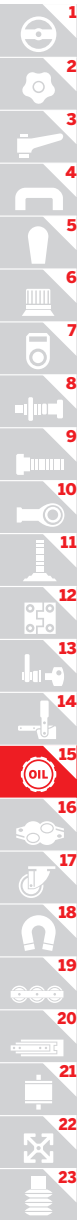

Accessories for hydraulic systems 15

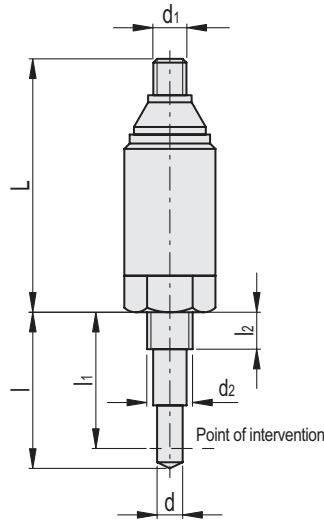
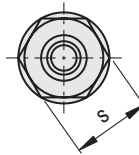

### HSC-W-A-KN

Code	Description	d <sub>2</sub>	d	L	l*	l <sub>1</sub>	l <sub>2</sub>	s	d <sub>1</sub>	⚖️
111255	HSC-W-1/4NPT-50-A-KN	1/4 NPT	6.5	64	50	40±2	10	24	M12x1	138

### HSC-W-D-KN

Code	Description	d <sub>2</sub>	d	L	l*	l <sub>1</sub>	l <sub>2</sub>	s	d <sub>1</sub>	⚖️
111256	HSC-W-1/4NPT-50-D-KN	1/4 NPT	6.5	64	50	40±2	10	24	M12x1	138

### HSC-O-A-KN

Code	Description	d <sub>2</sub>	d	L	l*	l <sub>1</sub>	l <sub>2</sub>	s	d <sub>1</sub>	⚖️
111245	HSC-O-1/4NPT-50-A-KN	1/4 NPT	6.5	64	50	40±2	10	24	M12x1	138

### HSC-O-D-KN

Code	Description	d <sub>2</sub>	d	L	l*	l <sub>1</sub>	l <sub>2</sub>	s	d <sub>1</sub>	⚖️
111246	HSC-O-1/4NPT-50-D-KN	1/4 NPT	6.5	64	50	40±2	10	24	M12x1	138

\* Probe length