

Linear guide rails

Flat profile, stainless steel, PEEK

GUIDE PROFILE

AISI 304 stainless steel with technopolymer coating (PEEK), grey colour.

BRACKET

Anodised aluminium.

FEATURES AND APPLICATIONS

GLF side guides are generally used to laterally guide bundles of heat-shrinkable polyethylene film on conveyor belts. The PEEK coating ensures minimal rolling resistance of the product and is also suitable for high-temperature applications.

Minimum coating thickness 40 μ , maximum 50 μ .

Supplied in bars of 1500 or 3000 mm length.

ACCESSORIES ON REQUEST

- GGLF: linear guide joint.
- TGLF: end cap.
- BDG: connecting plate for guides.
- MPG-P: guide fixing pins.
- MPG-V: hammer head screw.
- PGL-1: separation block for side guides.

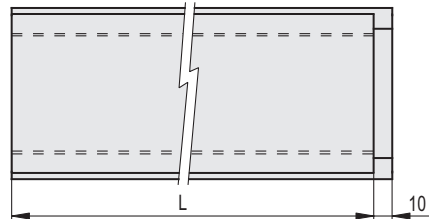
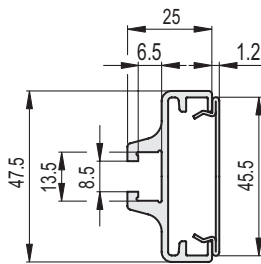
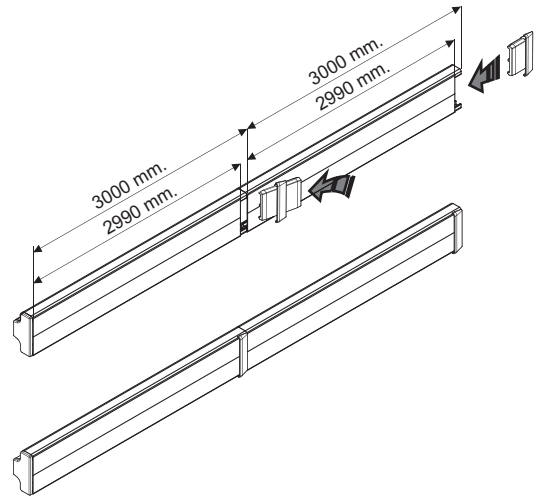
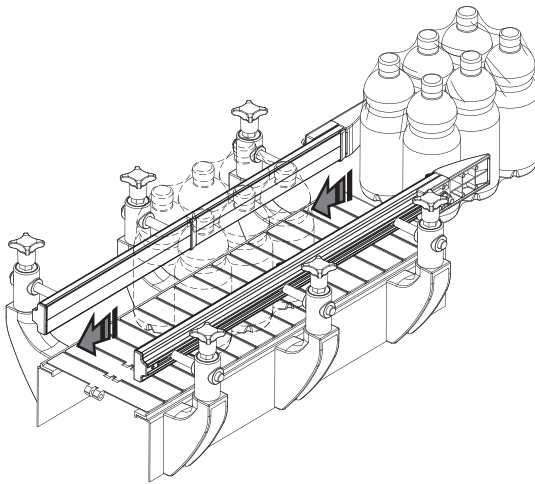

STAINLESS STEEL

| Code | Description | L | Δ |
|--------|-------------|------|----------|
| 419095 | GLF-46-1500 | 1500 | 1675 |
| 419096 | GLF-46-2990 | 2990 | 3350 |