

Mechanical position indicators

direct drive, 4-digit counter, technopolymer

BASE AND CASE

High-resistance polyamide based (PA) technopolymer. Black base.

Case in the following colours:

- **C2**: RAL 2004 orange, glossy finish.
- **C3**: RAL 7035 grey, glossy finish.
- **C1**: RAL 7021 grey-black, glossy finish.
- **C55**: RAL 5005 blue, glossy finish.

The ultrasonically welding between the base and the case prevents separation and avoids dust penetration.

WINDOW

Transparent polyamide based (PA-T) technopolymer, moulded over the case and with a perfect seal (avoid contact with alcohol during cleaning operations).

DISPLAY

It indicates the displacement of the mechanism controlled by the spindle from the start position (0).

Four-digit roller counter. The digits of red rolls show the decimal values. An additional graduated scale next to the last decimal digit offers further accuracy of reading.

The display can be in different positions (see "Example of description for ordering").

- **AN**: inclined display, counter in upper position.
- **AR**: inclined display, counter in lower position.
- **FN**: front display, counter in upper position.
- **FR**: front display, counter in lower position.

INTERNAL GASKET

O-ring front sealing in NBR synthetic rubber, between the case and the boss.

REAR GASKET

Foam polyethylene, supplied.

STANDARD EXECUTIONS

Bushing with $\varnothing 14$ mm H7 reamed hole, fitting to shaft by means of a supplied grub screw with hexagon socket and cup end, included in the supply.

- **DD51**: black-oxide steel boss.
- **DD51-SST**: AISI 303 stainless steel boss.

DIRECTION OF ROTATION

- **D**: clockwise. Increasing values with clockwise rotation of the boss.
- **S**: anti-clockwise. Increasing values with anti-clockwise rotation of the boss.

WEIGHT

42 grams.

FEATURES AND APPLICATIONS

Direct drive digital position indicators can be assembled on passing through spindles in any position to give direct reading of the positioning of a machine component. They are suitable also for motor driven applications (see "Example of description for ordering").

ERGONOMY AND DESIGN

Compact roller counter, ergonomically designed digits for rapid reading. The readability of the counter is increased by the magnifying window.



ELESA Original design

ASSEMBLY INSTRUCTIONS

1. Drill a $\varnothing 6$ mm by 10 mm hole in the body of the machine with a 22 mm centre distance from the spindle to fit the rear referring pin.
2. Set the spindle to the start or referring position.
3. Fit the indicator with the zeroed roller counter onto the spindle and make sure that the referring pin fit the hole.
4. Clamp the bushing to the spindle by tightening the grub screw with hexagon socket and cup end, according to UNI 5929-85.

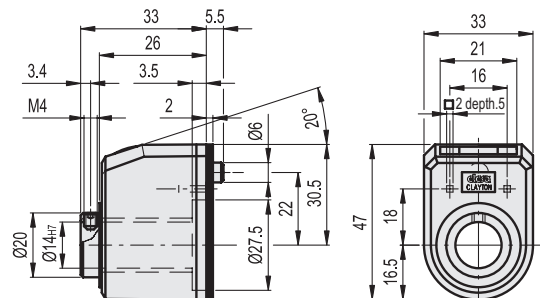
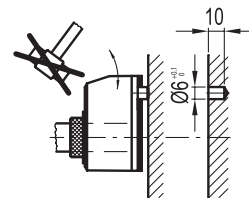

Example of description for ordering

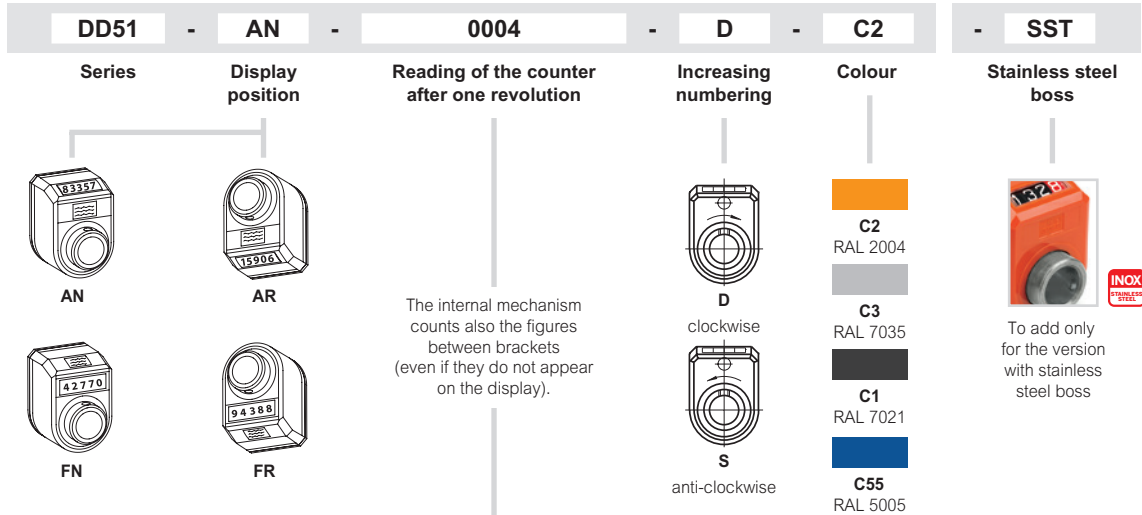

0 0 0 4	0 0 0 4	0 0 0 4	0 0 0 4	Pitch	Speed (rpm) *
0004	000.4	00.04	0.004	0.4	1500
0010	001.0	00.10	0.010	1.0	1500
0012(5)	001.2(5)	00.12(5)	0.012(5)	1.25	1500
0015	001.5	00.15	0.015	1.5	1500
0015(7)	001.5(7)	00.15(7)	0.015(7)	1.57	1500
0017(5)	001.7(5)	00.17(5)	0.017(5)	1.75	1420
0020	002.0	00.20	0.020	2.0	1250
0020(83)	002.0(83)	00.20(83)	0.020(83)	2.083	1200
0025	002.5	00.25	0.025	2.5	1000
0030	003.0	00.30	0.030	3.0	830
0040	004.0	00.40	0.040	4.0	625
0044	004.4	00.44	0.044	4.4	550
0050	005.0	00.50	0.050	5.0	500
0057	005.7	00.57	0.057	5.7	435
0060	006.0	00.60	0.060	6.0	415
0065(5)	006.5(5)	00.65(5)	0.065(5)	6.55	370
0075	007.5	00.75	0.075	7.5	330
0080	008.0	00.80	0.080	8.0	315
0083(3)	008.3(3)	00.83(3)	0.083(3)	8.33	300
0100	010.0	01.00	0.100	10.0	250
0120	012.0	01.20	0.120	12.0	205
0125	012.5	01.25	0.125	12.5	200
0157	015.7	01.57	0.157	15.7	150
0200	020.0	02.00	0.200	20.0	125

* The maximum rotation speed (rpm) of the spindle reported in the table corresponds to a maximum rotation of 25000 units of the last roll on the right of the counter. Rotational speed tests have been performed in our laboratory under standard operating conditions. Small misalignments (not compromising the correct reading) of counter digits can occur due to high tolerances between gear teeth, designed to prevent damage from sudden acceleration or stop.



Rotary controls 7

SPECIAL EXECUTIONS ON REQUEST

- Special readings after one revolution.
- Case in different colours.
- Completely sealed digital position indicators with IP 67 protection class, see EN 60529 table (on page) obtained by means of a brass bushing with double seal ring inside the rear cavity of the base.

LB - LOCKING DEVICE

The DD51-LB position indicators are designed to lock the spindle on which they are mounted to avoid the risk of accidental adjustment alterations due to vibrations. To lock or unlock the spindle rotation, simply move the lever, in pos. A equivalent to unlocked spindle, in pos. B equivalent to locked spindle.

Following repeated locking cycles, the special device is highly wear resistant and functions perfectly over time.

To order the indicator with spindle locking add the -LB index after the code and description (e.g. CE.84101-LB DD51-AN-00.50-D-C3-LB).

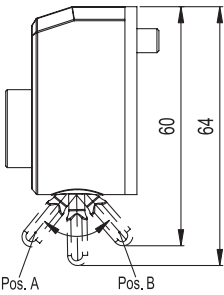

DD51-LB - with locking device

ACCESSORIES ON REQUEST (TO BE ORDERED SEPARATELY)

- **BSA-N51:** zinc die-cast bases for spindle locking, epoxy resin coating, black colour, matte finish (see table). GN 302.1 adjustable handle. BSA-N51 locking bases allow an easy and quick locking of the spindles after their positioning. They are equipped with a Ø 6.1 mm hole to fit the referring pin of the indicator. They can be assembled with the handle either on the right or on the left and can be fitted to the machine by means of two M4 cylindrical-head screws (not included in the supply).

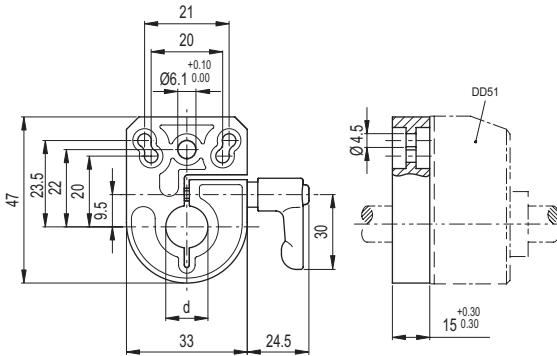

BSA-N51

Code	Description	dH7
CE.85915	BSA-N51-8	8
CE.85917	BSA-N51-10	10
CE.85919	BSA-N51-12	12
CE.85921	BSA-N51-14	14

- **BSA-T51:** shaft locking base in polyamide based (PA) SUPER-technopolymer, black colour, matte finish. BSA-T51 locking bases allow an easy and quick locking of the spindles after their positioning. They are equipped with a Ø 6.1 mm hole to fit the referring pin of the indicator. They can be assembled with the handle either on the right or on the left and can be fitted to the machine by means of two M4 cylindrical-head screws (not included in the supply).

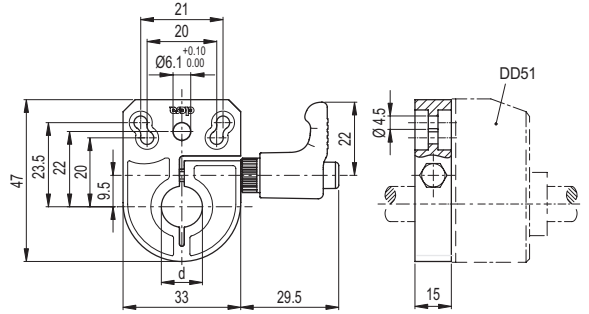

BSA-T51

STAINLESS STEEL

Code	Description	d	△
CE.95931	BSA-T51-6-SST	6	36
CE.95932	BSA-T51-8-SST	8	35
CE.95933	BSA-T51-10-SST	10	34
CE.95934	BSA-T51-12-SST	12	33
CE.95935	BSA-T51-14-SST	14	32

- **BS51:** glass-fibre polyamide based (PA) technopolymer spacer plate (code CE.85900).

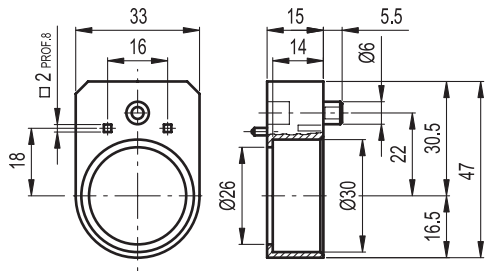

- **MDX-51:** polyamide based (PA) technopolymer knob.



- **RB51:** black-oxide steel reduction sleeves.
- **RB51-SST:** AISI 304 stainless steel reduction sleeves.

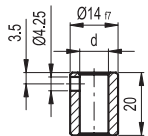

RB51

Code	Description	dH7
CE.85940	RB51-6	6
CE.85950	RB51-8	8
CE.85955	RB51-10	10
CE.85960	RB51-12	12

RB51-SST

STAINLESS STEEL

Code	Description	dH7
CE.95941	RB51-6-SST-304	6
CE.95951	RB51-8-SST-304	8
CE.95956	RB51-10-SST-304	10
CE.95961	RB51-12-SST-304	12